



Description

SLM6305 is a 2.5A lithium ion battery charger with wide voltage input. It is a synchronous buck converter with a fixed frequency of 550kHz. It has a charging efficiency of more than 90% and a very small calorific value.

SLM6305 integrates 28V high-voltage devices, which can effectively prevent chip is damaged by surge voltage or incorrect connection of high-voltage adapter, and has high security.

The SLM6305 includes a complete charging termination circuit, automatic recharging and a 4.2V preset charging voltage with an accuracy of $\pm 1\%$. The SLM6305 has many functions, such as anti back filling protection, output short circuit protection, chip and battery temperature protection.

SLM6305 is packaged in a miniaturized DFN3x3-10L package, which requires only a small number of peripheral components and a very small area of PCB board. Therefore, SLM6305 can be embedded in various handheld applications as an efficient charger for large capacity batteries.

Maximum Rating

- Input power voltage(V_{IN}): -0.3V~28V
- VGC: $V_{IN}-7V\sim V_{IN}+0.3V$
- NCHRG、NSTDBY: -0.3V~28V
- BAT: -0.3V~14V
- VS: -0.3V~14V
- LX: -0.3V~14V
- Others: -0.3V~7V
- Short circuit duration of BAT: continuous
- Maximum junction temperature: 145°C
- Working environment temperature range: -40°C~85°C
- Storage temperature range: -65°C~125°C
- Welding temperature (10 seconds):260°C

Features

- Maximum working voltage is 26.0V and the withstand voltage is 28V
- Fixed switching frequency of 550kHz
- High output efficiency of more than 90%
- Maximum adjustable output current of 2.5A
- Automatic identification of input current and adaptive adapter
- There is no need to prevent reverse current diode
- No external power MOS transistor or freewheeling diode is required
- Accuracy of 4.2V charging voltage with accuracy of $\pm 1\%$
- It can withstand 28V high voltage charging state dual indication output
- Shutdown current is only 20uA
- 2.9V trickle charging
- Soft start limits surge current
- Battery temperature monitoring function
- Output short circuit protection function
- DFN3x3-10L package

Applications

- Electronic cigarette
- Electric toys
- Power tools
- MP3 and MP4 players
- Digital camera
- Electronic dictionary
- GPS
- Portable equipment, various chargers

Complete Charge Cycle

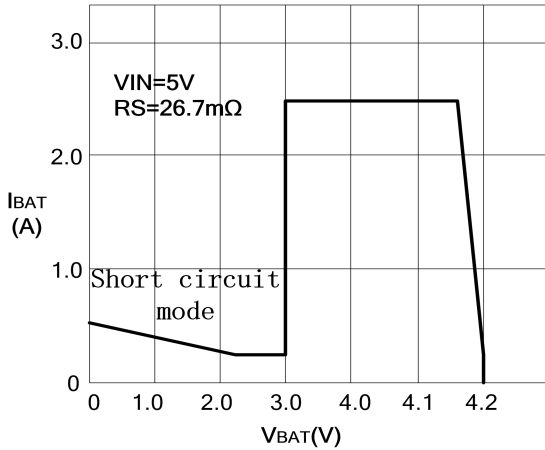

Figure 1

the heat sink at the bottom. As the main radiator of IC, the copper foil of PCB board should be as wide as possible, and extend outward to the larger copper foil area, so as to spread the heat to the surrounding environment.

Placing vias in the PCB to the inner layer or back layer also has a significant effect on improving the overall thermal performance of the charger, as shown in Figure 3. A 1.7mm * 3.0 mm square pad is placed at the SLM6305 position of PCB board as the heat sink of SLM6305, and several through holes of 0.8 mm diameter are placed on the pad as heat dissipation holes. When chip is welded, solder is poured into the back layer of PCB to effectively connect the heat sink at the bottom of SLM6305 and the heat sink of PCB board, so as to ensure the efficient heat dissipation of SLM6305. **The efficient heat dissipation of the chip is the premise of maintaining a large charging current for a long time.**

Typical Application

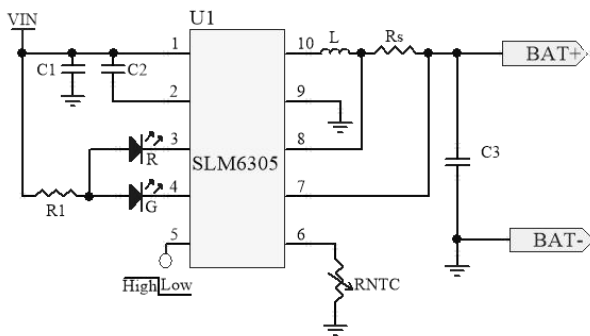

Figure 2

Application Tips

The efficient heat dissipation of the chip is the premise of maintaining a large charging current for a long time.

DFN3x3-10L package has a small size, so the layout of PCB board should be paid special attention to in consideration of heat dissipation. The heat dissipation path for dissipating heat generated by IC is from the chip to the lead frame, and reaches the copper surface of PCB through

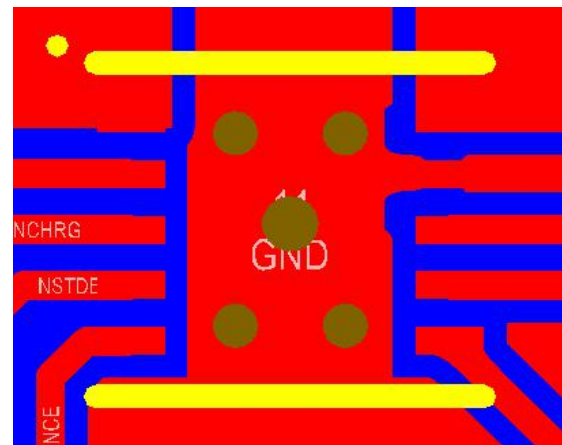

Figure 3

When PCB layout is designing, other heat sources independent of charging IC should be considered, because their own temperature will affect the overall temperature rise and maximum charging current.

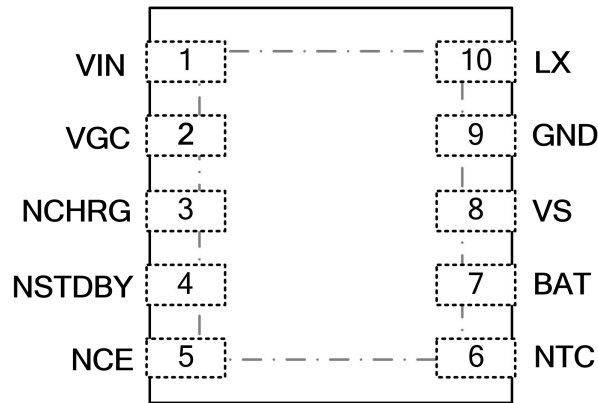

Figure 4. SLM6305 Pin package

PIN	Symbol	Function
1	VIN	Input power terminal
2	VGC	Internal drive clamp end
3	NCHRG	Battery charging indicating terminal
4	NSTDBY	Battery charging completion indicator
5	NCE	Enable control terminal
6	NTC	Battery temperature detection input
7	BAT	Battery voltage detection terminal
8	VS	Battery current detection terminal
9	GND	Land
10	LX	Switch end

PIN Configuration

VIN (PIN 1): Input voltage terminal, the maximum withstand voltage of this terminal is 28V, and the charging working voltage is 4.6 ~26.0V.

VGC (PIN 2): Gate voltage clamp of internal driving tube, and a capacitance of 0.1uF is connected between this end and VIN.



SLM6305

28V Synchronous Buck Li-Battery Charger

NCHRG (PIN 3): State of charge indication terminal. When the charger charges the battery, the PIN is pulled to the low level by the internal switch, indicating that the charging is in progress, otherwise the PIN is in the high resistance state.

NSTDBY(PIN 4): Charging completion indication terminal. When the battery charging is completed, the PIN is pulled to the low level by the internal switch, indicating that the charging is completed; otherwise, the PIN is in the high resistance state.

NCE(PIN 5): Enable control terminal. The input low level will make the chip in the normal working state; the input high level will make the chip in the charging forbidden state. NCE PIN can be driven by TTL level or CMOS level.

NTC (PIN 6): Battery temperature detection input. Connect the PIN to the output terminal of the NTC sensor of the battery. If the voltage of NTC PIN is less than 180mV or greater than 1.35v, it means that the battery temperature is too high or too low, and charging is suspended. If the NTC is suspended, the battery temperature detection function is cancelled and other charging functions are normal.

BAT (PIN 7): Battery voltage detection terminal. When the charging is stopped, the leakage current of bat PIN is less than 3uA.

VS (PIN 8): Battery current detection terminal. A high-precision milliohm resistor R_S is connected between this terminal and bat, which is used to set the charging current during fast charging. The calculation formula is $I_{BAT} = 0.0667 \div R_S$ (A)

GND (PIN 9): Power ground. The GND terminal must be reliably connected with the heat sink at the bottom of the chip and the copper laying on the PCB board.

LX (PIN 10): Built in power MOSFET connection point. LX is the current output terminal of SLM6305, which is connected with external inductance as the input of battery charging current.

Electrical Characteristics

(Unless otherwise specified, $V_{IN} = 5V \pm 2\%$, NCE connected with GND, $T_A = 25^\circ C$)

Symbol	Parameter	Condition	Min	Typ	Max	Unit
V_{IN}	Input power voltage		4.6	5	26	V
V_{UV}	V_{IN} under voltage blocking threshold	From V_{IN} high to low	3.8	3.95	4.1	V
V_{UVHYS}	V_{IN} under voltage locking hysteresis			300		mV
I_{IN}	Input power current	Standby mode (charging)		130	260	uA



SLM6305

28V Synchronous Buck Li-Battery Charger

		termination)				
		Shutdown mode (NCE is high)		20	40	uA
V _{FLOAT}	Fully charged (floating charge) voltage		4.158	4.2	4.242	V
I _{BAT}	BAT pin current: (current mode test condition is V _{BAT} = 3.8V)	Rs = 33.3m Ω, current mode	1.8	2.0	2.2	A
		Standby mode, V _{BAT} = 4.2V		2.3	4.6	uA
		Stop mode (V _{IN} < V _{BAT} or V _{IN} < V _{UV})		2.6	5.2	uA
		Shutdown mode (NCE is high)		0		uA
I _{TRIKL}	Trickle charge current	V _{BAT} < V _{TRIKL} Rs = 33.3m Ω, current mode		200		mA
V _{TRIKL}	Trickle charging threshold voltage	V _{BAT} up	2.7	2.85	3.0	V
V _{TRHYS}	Trickle charge hysteresis voltage			100		mV
V _{BLV}	Threshold voltage of battery short circuit protection			2.2		V
V _{INSL}	Input voltage drop protection			4.55		V
V _{ASD}	V _{IN} -V _{BAT} Blocking threshold voltage	V _{IN} from low to high	150	200	300	mV
		V _{IN} from high to low	10	80	130	mV
I _{TERM}	Charging termination current threshold	Rs =33.3mΩ	100	200	300	mA
V _{NSTDBY}	NSTDBY pin output low voltage	I _{NSTDBY} =5mA		0.5		V
V _{NCHRG}	NCHRG pin output low voltage	I _{NCHRG} =5mA		0.5		V
I _{NTC}	NTC pin current		45	50	55	uA



SLM6305

28V Synchronous Buck Li-Battery Charger

V_{NCE_L}	NCE pin low enable level				0.8	V
V_{NCE_H}	NCE pin high enable level		2.5			V
V_{NTCH_HYS}	High end turnover voltage hysteresis of NTC pin			50		mV
V_{NTC_L}	Turn over voltage at the low end of NTC pin			180		mV
V_{NTCL_HYS}	Turn over voltage hysteresis at the low end of NTC pin			40		mV
ΔV_{RECHRG}	Threshold voltage of rechargeable battery		100	150	250	mV
FREQ	Oscillation frequency		450	550	650	kHz
R_{PFET}	PMOSFET "on" resistance			100		m Ω
R_{NFET}	NMOSFET "on" resistance			100		m Ω
t_{LIM}	Junction temperature in limited temperature mode			145		$^{\circ}C$
t_{SS}	Soft start time		300			us
t_{RECHRG}	Filter time of recharging comparator	V_{BAT} from high to low		1		ms
t_{TERM}	Stop comparator filtering time	I_{BAT} drops below I_{TERM}		1		ms

Principle

SLM6305 is a 2.5A lithium ion battery charger with wide voltage input. It uses 550kHz fixed frequency synchronous buck converter and uses the power transistor inside the chip to charge the battery trickle current, constant current and constant voltage. The charging current can be programmed with external resistance, and the maximum continuous charging current can reach 2.5 A without additional anti backflow diode. It has a charging efficiency of more than 90% and its own calorific value is very small.

SLM6305 integrates 28V high-voltage devices, which can effectively prevent chip is damaged by surge voltage or incorrect connection of high-voltage adapter, and has high security.

SLM6305 consists of two state indicating terminals with open drain output, charging state indicating terminal NCHRG and fully charged state indicating terminal NSTDBY. These two indicating terminals can withstand 28V high voltage, so that the indicator light can be directly connected with VIN through current limiting resistor. The power management circuit in the chip automatically reduces the charging current when the junction temperature exceeds 145°C. This function enables users to make maximum use of the chip processing capacity, without worrying about the chip overheating and damaging the chip or external components.

When the input voltage is greater than the under voltage detection threshold and lower than the over voltage detection threshold, and the NCE terminal is at low level, SLM6305 starts to charge the battery, and NCHRG PIN outputs low level, indicating that charging is in progress. The charging current is set by the resistance R_s connected between vs and bat. If the battery

voltage is lower than V_{TRIKL} , the charger uses a small current to pre charge the battery trickle. When the battery voltage is higher than V_{TRIKL} , the charger switches to fast charging state. When the battery voltage is close to 4.2V, the charging current will gradually decrease, and SLM6305 will enter the constant voltage charging mode. When the charging current decreases to the end of charging threshold, the charging cycle is over, the NCHRG terminal outputs the high resistance state, and the NSTDBY terminal outputs the low level. The end of charge threshold is I_{TERM} .

When the battery voltage drops below the recharging threshold, SLM6305 automatically starts a new charging cycle. The high-precision voltage reference, error amplifier and resistance divider network ensure that the accuracy of the voltage modulation at the battery terminal is less than 1%, which meets the requirements of accurate charging of lithium-ion batteries. When the input voltage is down or the input voltage is lower than the battery voltage, the charger will enter the sleep mode with low power consumption, and the current consumed by the battery terminal is less than 3uA, which increases the standby time.

Charging Current Setting

The I_{BAT} of battery charging is set by the resistance R_s connected between pin vs and bat, and the relationship between them can be calculated by the following formula:

$$I_{BAT} = 0.0667 \div R_s$$

For example: it is necessary to set the charging current to 2.0A. According to the above formula, $r_s = 33.3m\Omega$ can be calculated, which is equivalent to a 50mΩ and a 100mΩ resistor in parallel.

Charging Termination

When the charging current drops to about I_{TERM} after reaching the final full voltage, the charging cycle is terminated.

There is a charging voltage and current monitoring module in the chip. When the charging voltage reaches V_{FLOAT} , the charging current is lower than I_{TERM} and the duration is t_{TERM} , the SLM6305 will terminate the charging cycle, in this state, all loads on bat pins must be powered by batteries.

However, if the chip reaches t_{LIM} or the input voltage drops to V_{INSL} , the internal charging termination module will be disabled to prevent the battery from being fully charged due to temporary protective measures.

Charging State Indication

SLM6305 has two drain open status indication outputs. NCHRG and NSTDBY.

In general, NCHRG is connected with red LED and NSTDBY is connected with green indicator.

When the battery is in charging state, NCHRG is pulled to low level, the red light is on, NSTDBY is in high resistance state, and the green light is off. When the battery is fully charged, NSTDBY is pulled to low level, green light is on, NCHRG is in high resistance state, and red light is off.

If SLM6305 is in V_{IN} under voltage or over-voltage protection, NCE is high, battery short circuit or NTC state is abnormal, NCHRG and NSTDBY are in high resistance state at the same time, and both lights are off.

If the battery is not connected, the green light is always on and the red light is flashing. The flashing period is related to the capacitance of bat terminal and leakage current, which is generally

1-4 seconds.

State of charge	Red light NCHRG	Green light NSTDBY
Charge	Bright	Extinguish
The battery is fully charged	Extinguish	Bright
Battery not connected	Twinkle	Bright
Under voltage or over-voltage, NCE is high, battery short circuit or NTC status is abnormal	Extinguish	Extinguish

Input Adaptive Protection

SLM6305 has adapter adaptive function to meet different types and current capacity of the adapter.

SLM6305 continuously monitors the input voltage at VIN terminal. When the voltage drops to V_{INSL} , the internal feedback loop will reduce the charging current to prevent the VIN terminal voltage from further decreasing and protect the adapter from damage due to overload. In the adaptive protection state, all charging functions will continue to work.

Over Temperature Protection

If the chip temperature rises above the preset value of 140°C , an internal thermal feedback loop will reduce the charging current until the current decreases to 0 above 150°C . This function can prevent the SLM6305 from overheating and allow users to improve the power processing capacity of a given circuit board within the allowable range of SLM6305.

Battery Temperature Monitoring

In order to prevent the battery from being damaged by too high or too low temperature, a battery temperature monitoring circuit is integrated in the SLM6305.

The battery temperature monitoring is realized by monitoring the thermistor with negative temperature coefficient close to the battery. The thermistor is connected between NTC and GND.

In the chip, the NTC pin is connected to the input of two voltage comparators, and its low voltage threshold is V_{NTC_L} . The high voltage threshold is V_{NTC_H} . Corresponding to the lower limit of normal temperature range. If the voltage of NTC PIN is within this range, the chip will be charged normally. Otherwise, the battery temperature is too high or too low, and the charging process will be suspended.

The pull-up current of NTC PIN is 50uA, so the value of negative temperature coefficient thermistor should be 10k Ω at 25 $^{\circ}$ C, 3.6k Ω at upper temperature point and 27k Ω at lower temperature point. Users can choose the right model according to their specific needs.

If the upper or lower temperature protection points need to be adjusted, the user can achieve this by parallel connection or series connection of a common resistor with the thermistor.

If the battery temperature monitoring function is not used, just hang the NTC pin in the air or connect a resistance of more than 1M Ω to GND.

Current limiting And Output Short Circuit Protection

SLM6305 is integrated with multiple protections. The maximum peak current at the input end of the chip is 4.5A to prevent chip is damaged by excessive current. When the output

voltage is lower than 2.2V, the chip enters the short-circuit protection mode, and the output current of the chip is about 100 ~ 300mA.

Automatic Recharge

After a charging cycle is completed, SLM6305 uses a comparator with a filter time of about 1ms (t_{rechg}) to continuously monitor the voltage on the bat pin. When the battery voltage decreases ΔV_{rechg} (approximately 80% to 90% of the battery capacity), the charging cycle starts again. This ensures the need for the battery to be activated by a maintenance charging cycle. During the recharging process, the NCHRG PIN output enters the strong pull-down state, and the NSTDBY PIN is in the high resistance state.

White LED Driver

The output of SLM6305 directly drives WLED, and the white LED is in the constant current stage because the working voltage of white LED is about 3.6V. SLM6305 can provide efficient and stable driving current for a single white LED or multiple white LED in parallel, and has an output voltage limiting protection of 4.2V. The adjustment of driving current can drive 3w-11w white LED according to R_s setting.

Input And Output Capacitance

Many types of capacitors can be used, but high quality power capacitors are required. It is particularly important to be careful when using multilayer ceramic capacitors. Some types of ceramic capacitors have the characteristics of high EMI value. Therefore, under certain conditions (such as connecting the charger input with a working power supply), high voltage transient signal may be generated to damage the chip.

When 2A is applied, it is recommended to use 22uF chip capacitor at the input end and 22uF chip capacitor at the output end Electrolytic capacitor, need to add a 0.1uF electrolytic capacitor for bypass, and the link position must be close to the chip pin. In addition, if it is necessary to consider the possibility of high voltage input, the capacitor must also consider the withstand voltage problem.

Inductance Selection

In order to ensure the stability of the system, the system needs to work in continuous mode (CCM) in the pre charging and constant current charging stages. According to the inductance current formula:

$$\Delta I = \frac{1}{L \times FS} \left(\frac{V_{IN} - V_{BAT}}{V_{IN}} \right) \times V_{BAT}$$

Where ΔI is the inductance ripple and FS is the switching frequency. In order to ensure that both pre charging and constant current charging are in CCM mode, ΔI is 1/10 of constant current charging, the inductance can be calculated according to the input voltage.

The inductance is 2.2uH ~ 10uH.

The rated current of inductor should be larger than the charging current and the power inductance with smaller internal resistance should be selected.

Thermal Considerations

DFN3x3-10L package has a small size, so the layout of PCB board should be paid special attention to in consideration of heat dissipation. It is important to maximize the available charging current. The heat dissipation path for dissipating heat generated by IC is from the chip to the lead frame, and reaches the copper surface of PCB through the heat sink at the bottom. As the main

radiator of IC, the copper foil of PCB board should be as wide as possible, and extend outward to the larger copper foil area, so as to spread the heat to the surrounding environment.

Placing vias in the PCB to the inner layer or back layer also has a significant effect on improving the overall thermal performance of the charger, as shown in Figure 3. A 1.7mm * 3.0 mm square pad is placed at the SLM6305 position of PCB board as the heat sink, and several through holes with 0.8 mm diameter are placed on the pad as heat dissipation holes. During chip welding, solder is poured into the back layer of PC to effectively connect the heat sink at the bottom of SLM6305 and the heat sink of PC board, so as to ensure the efficient heat dissipation of SLM6305. The efficient heat dissipation of the chip is the premise of maintaining a large charging current for a long time.

When designing PCB layout, other heat sources independent of charging IC should be considered, because their own temperature will affect the overall temperature rise and maximum charging current.

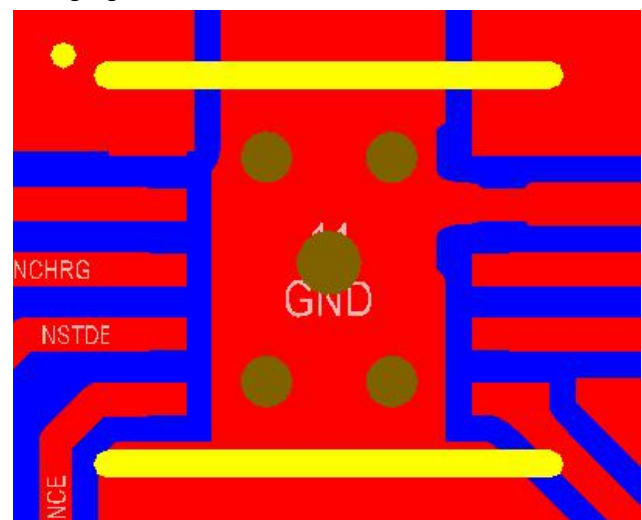

Figure 5 PCB layout

Expand Application

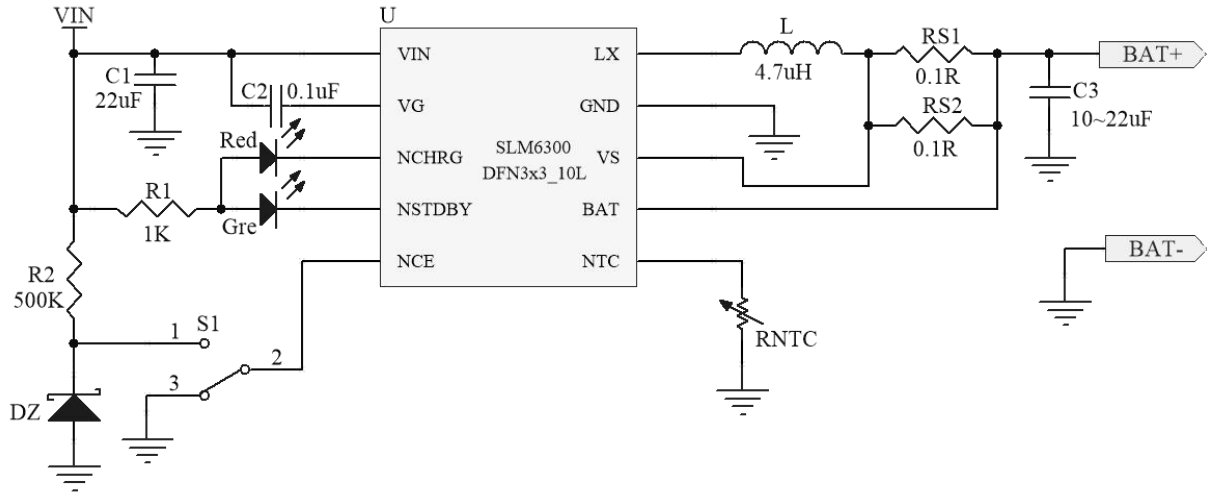
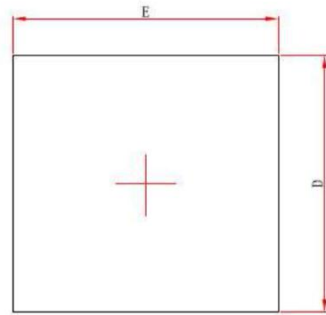
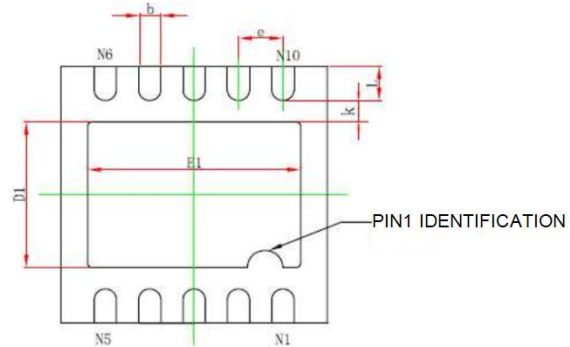

Figure 6 Extended application

DFN3x3-10L package



Top View



Bottom View

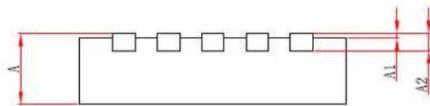

Side View

Symbol	Dimensions In Millimeters		Dimensions In Inches	
	Min	Max	Min	Max
A	0.700/0.800	0.800/0.900	0.028/0.031	0.031/0.035
A1	0.000	0.050	0.000	0.002
A2	0.153	0.253	0.006	0.010
D	2.900	3.100	0.114	0.122
E	2.900	3.100	0.114	0.122
D1	1.600	1.800	0.063	0.071
E1	2.300	2.500	0.091	0.098
k	0.200MIN		0.008MIN	
b	0.200	0.300	0.008	0.012
e	0.500TYP		0.020TYP	
L	0.300	0.500	0.012	0.020